

HC5 LCD

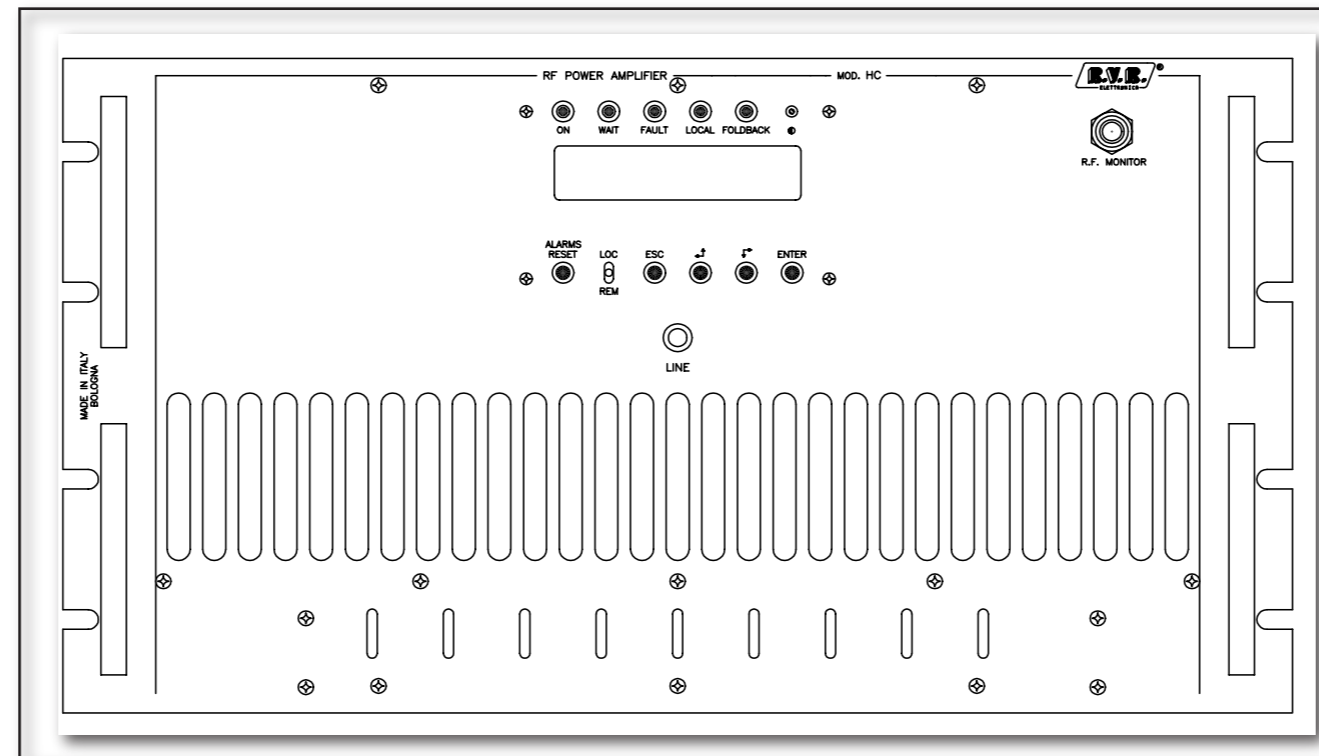

User Manual Volume 2: Technical Appendix

Appendix A Piani di montaggio, schemi elettrici, liste componenti / *Component layouts, schematics, bills of material*

Questa parte del manuale contiene i dettagli tecnici riguardanti la costruzione delle singole schede componenti il HC5 LCD. L'appendice è composta dalle seguenti sezioni:

This part of the manual contains the technical details about the different boards of the HC5 LCD. This appendix is composed of the following sections:

Description	RVR Code	Vers. Page	
Wiring diagrams	KCABHC5/1LCD	2.2	1
Power Splitter & Ext. Phase Adj.	SLSPLHC5/1LC	2.0	3
Power Combiner	SLCMB1HC5LCD	2.0	5
Unbal Power Card	SLPWRSNHC01	1.0	8
CPU Section	SLPROTPJ-HCL	3.0	10
Remote Card	SLSMT2HC5-5	2.1	16
EMI Filter	SLADPCNPRTPJ	2.1	18
Power Meter Card	SLPWRMTRHC5	1.0	20
Sonda Termica	SLSONDTERM	2.0	22

Document History

Date	Version	Reason	Code	Editor
17/06/03	2.0	First Release in A3 Format	N.D.	G. De Donno
08/09/03	2.1	Minor Corrections	N.D.	J.H. Berti
02/11/05	2.2	Unbal Power Card Upgrade	N.D.	J.H. Berti
03/03/06	2.3	Power Meter and Remote card Upgrade	RM 0106/0306	J.H. Berti

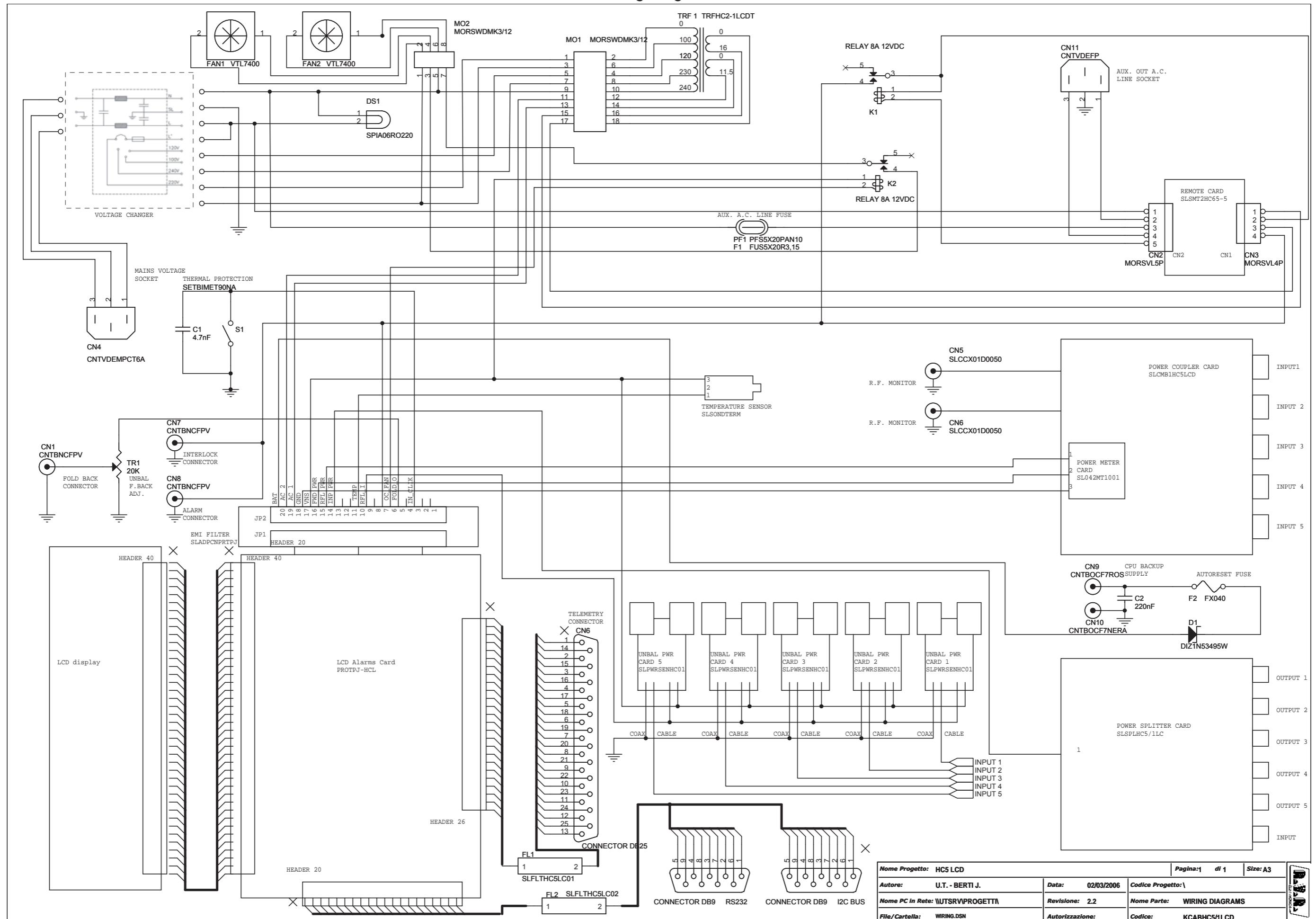

KCABHC5/1LCD
Revised: 03/03/06
Revision: 2.2
U.T. - Rev. J.Berti

Item	Quantity	Reference	Part
1	3	CN1, CN7, CN8	CNTBNCFPV
2	1	CN6	CONNECTOR DB25
3	1	C1	4.7nF
4	1	C2	220nF
5	1	CN2	MORSVL5P
6	1	CN3	MORSVL4P
7	1	CN4	CNTVDEMPCT6A
8	2	CN5, CN6	SLCCX01D0050
9	1	CN9	CNTBOCF7ROS
10	1	CN10	CNTBOCF7NERA
11	1	CN11	CNTVDEFP
12	1	DS1	SPIA06RO220
13	1	D1	DIZ1N53495W
14	2	FAN1, FAN2	VTL7400
15	1	FL1	SLFLTHC5LC01
16	1	FL2	SLFLTHC5LC02
17	1	F1	FUS5X20R3,15
18	1	F2	FX040
19	1	TR1	20K
20	2	K1, K2	RELAY 8A 12VDC
21	2	MO1, MO2	MORSWDMK3/12
22	1	PF1	PFS5X20PAN10
23	1	S1	SETBIMET90NA
24	1	TRF 1	TRFHC2-1LCDT

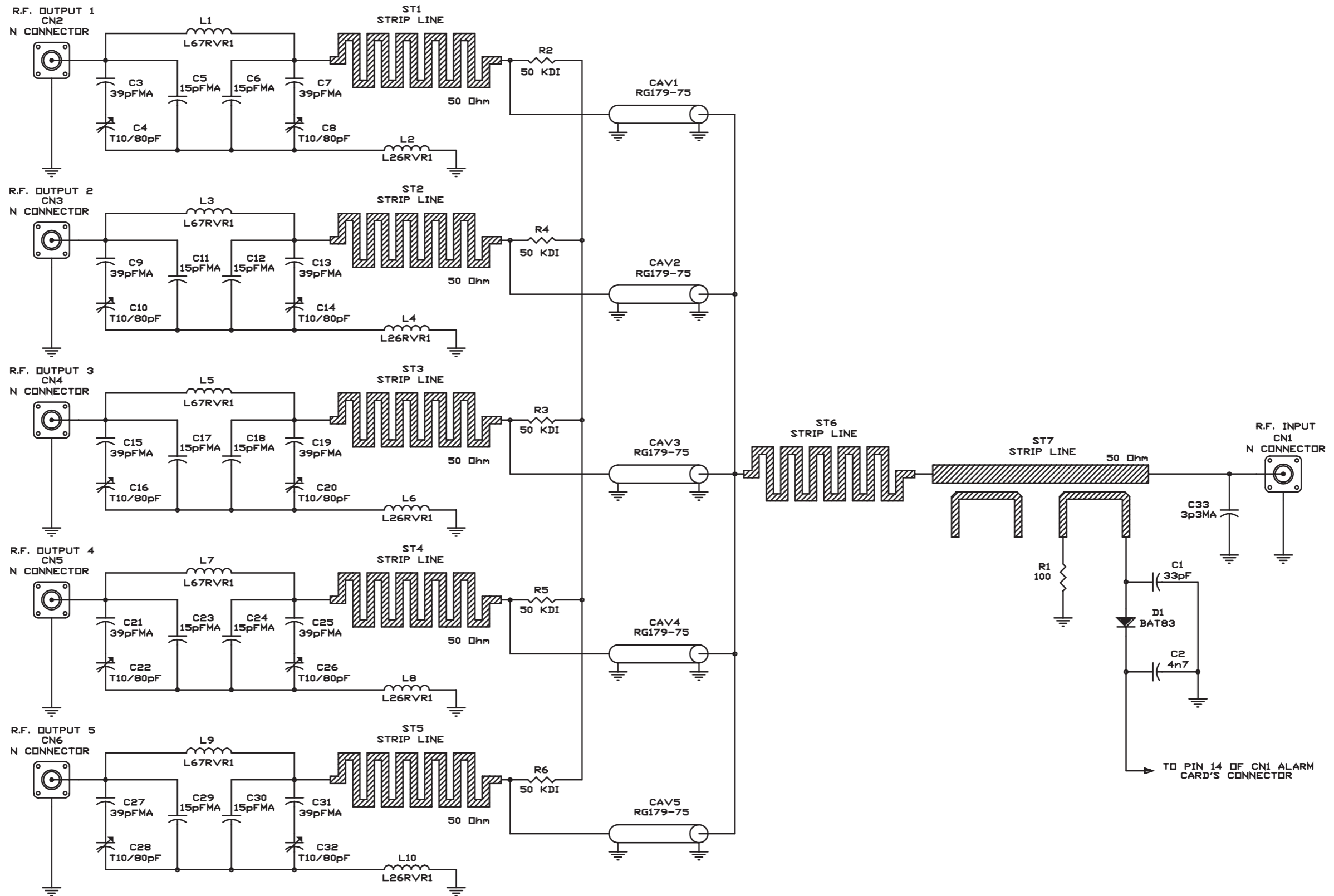

Nome Progetto:	HC5 LCD	Pagina:	1 di 1	Stato:	A2
Autore:	Ufficio Tecnico	Data:	17/06/03	Codice Progetto:	PFHC5/SLCD
Nome PC in Rete:	\\UT_SRV\PROGETTI	Revisione:	2.0	Nome Parte:	POWER SPLITTER Ψ. EXT. PHASE ADJ.
File/Cartella:	MANUALI\HC5LCD\SLSPLHC5/1LC\SCHSPL.DWG	Autore/Revisione:		Codice:	SLSPLHC5/1LC
Scala/		Titolare/		Profilo/	

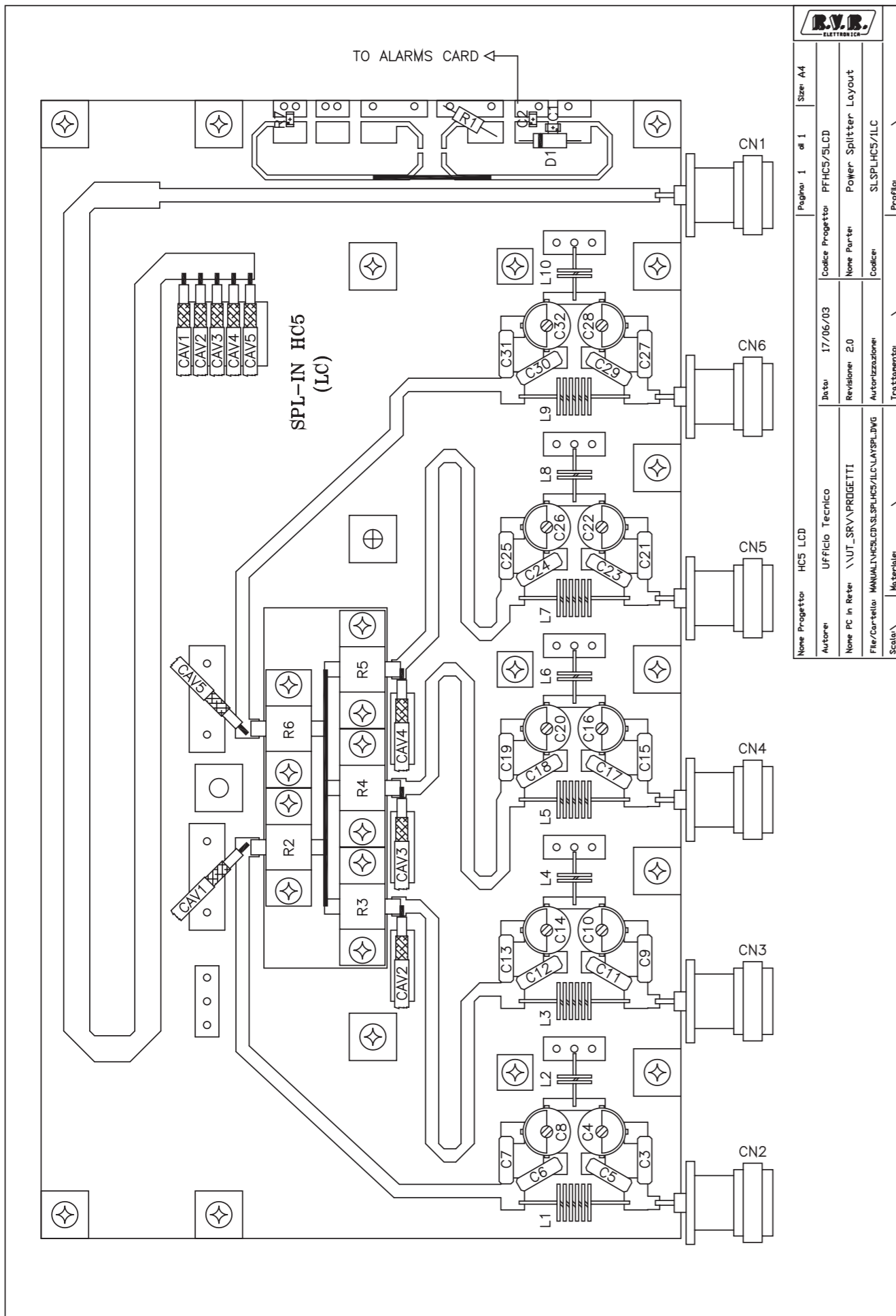

HYBRID POWER SPLITTER - Bill Of Materials

Item	Q.ity	Reference	Part	DESCRIPTION
1	5	R2,R3,R4,R5,R6	50 KDI	RES. DI TERM. (KDI)
2	1	R1	100	RESISTOR 1/4W 5%
3	1	C33	3P3HQ	CERAMIC CAPACITOR HQ
4	10	C4,C8,C10,C14,C16,C20,C22,C26,C28,C32	T10/80PF	TRIMMER CAPACITOR
5	10	C5,C6,C11,C12,C17,C18,C23,C24,C29,C30	15PFHQ	CERAMIC CAPACITOR HQ
6	10	C3,C7,C9,C13,C15,C19,C21,C25,C27,C31	39PFHQ	CERAMIC CAPACITOR HQ
7	1	C1	33PF	CERAMIC CAPACITOR NP0
8	1	C2	4N7	CERAMIC CAPACITOR
9	5	L2,L4,L6,L8,L10	L26RVR1	6 SP DIA 7 RAME SMAL 1.0mm
10	5	L1,L3,L5,L7,L9	L67RVR1	6 SP DIA 7 RAME SMAL 1.0mm
11	5	CAV1,CAV2,CAV3,CAV4,CAV5	COAX CABLE	RG179 75 Ohm
12	6	CN1,CN2,CN3,CN4,CN5,CN6	CNTNFPFLPI	CONN. N A TELAIO
13	1	D1	BAT83	HOT CARRIER DIODE
14	7	ST1,ST2,ST3,ST4,ST5,ST6,ST7	STRIP LINE	STRIP LINE

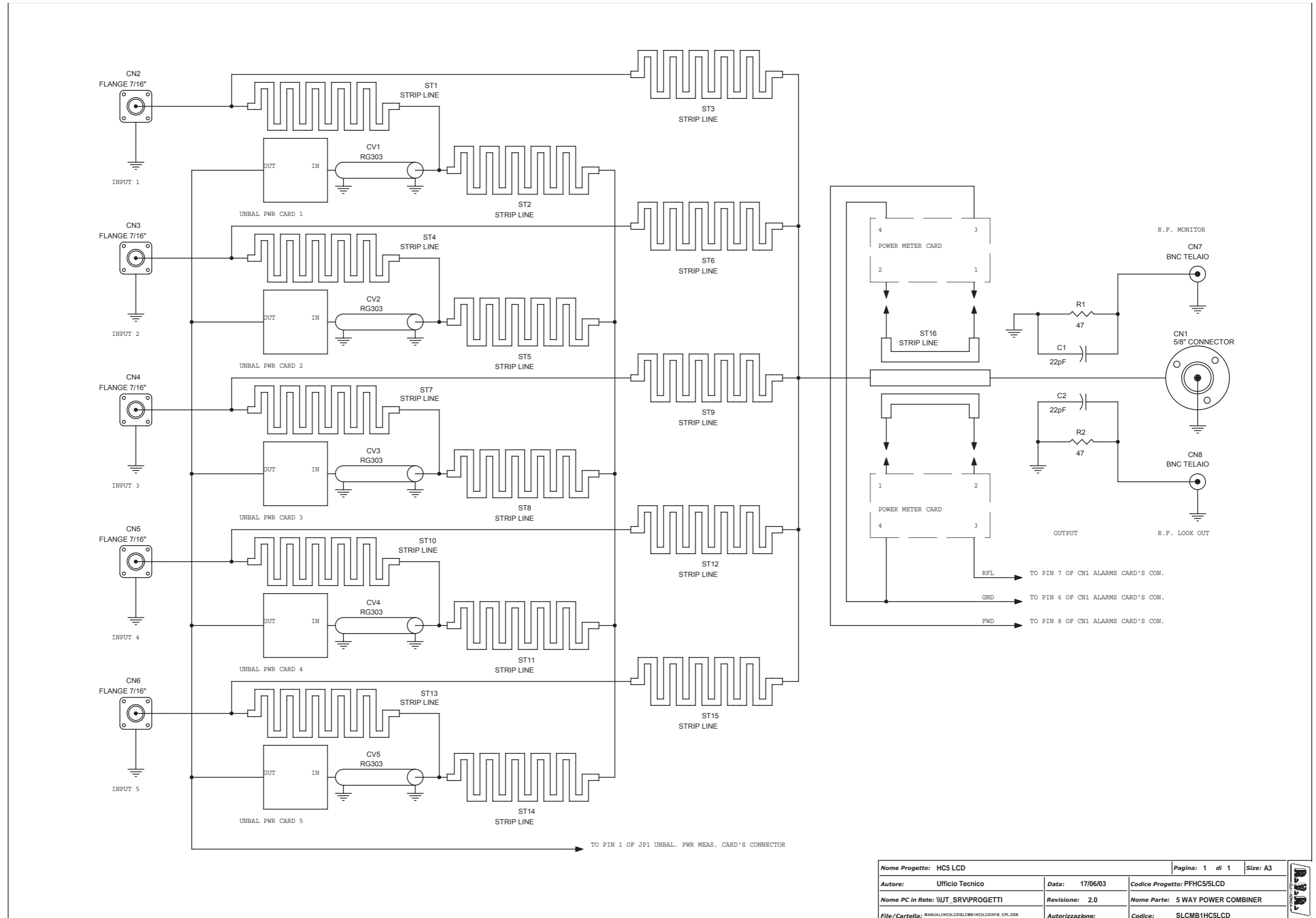

Nome Progetto: HC5 LCD		Pagina: 1 di 1	Size: A3
Autore: Ufficio Tecnico	Data: 17/06/03	Codice Progetto: PFHC5/5LCD	
Nome PC in Rete: \UT_SRV\PROGETTI	Revisione: 2.0	Nome Parte: 5 WAY POWER COMBINER	
File/Cartella: \MANUAL\HC5LCD\SLCMB1HC5LCD\HYB_CPL.DSN	Autorizzazione:	Codice: SLCMB1HC5LCD	

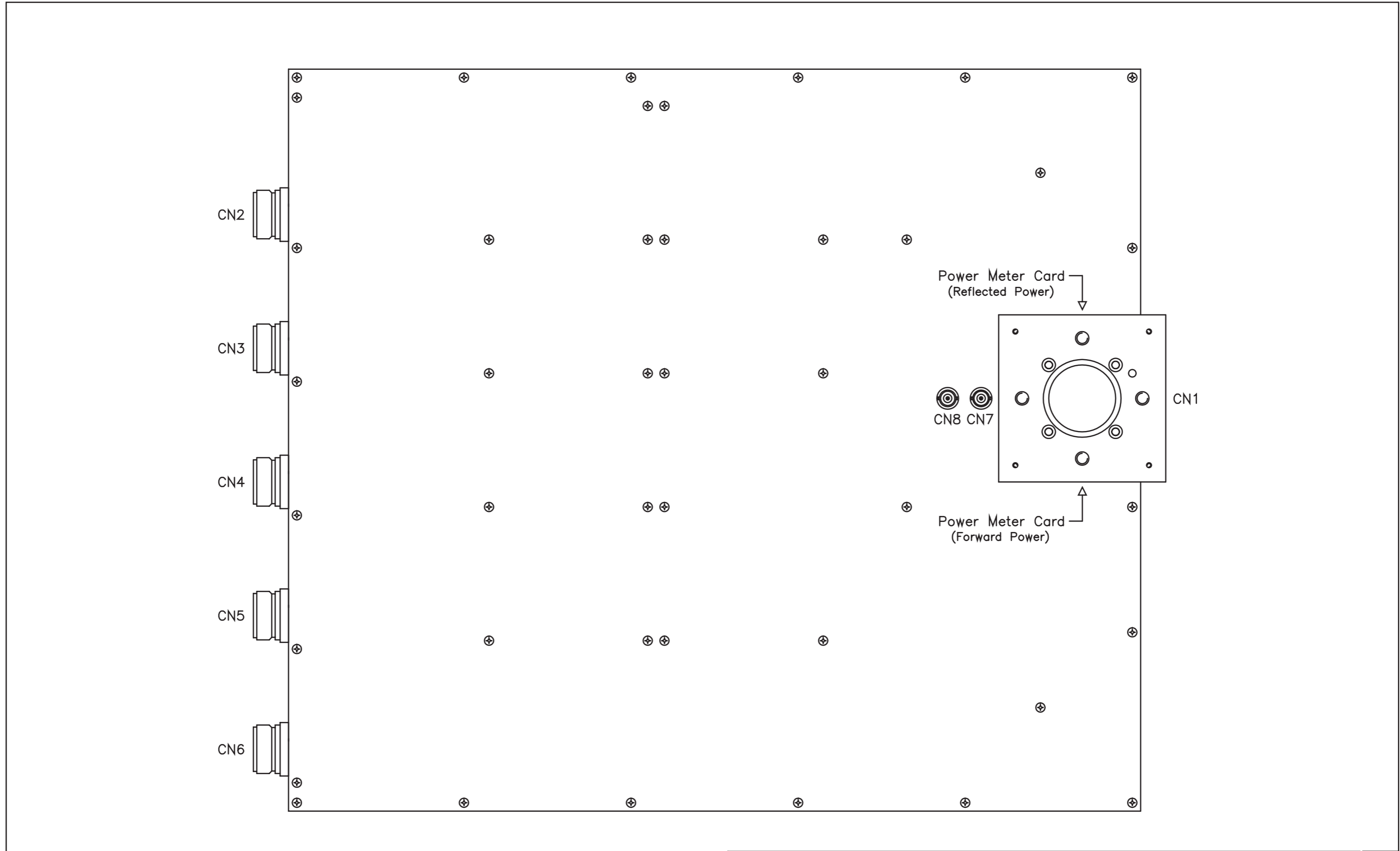

Nome Progetto: HC5 LCD		Pagina: 1 di 1		Size: A3
Autore: Ufficio Tecnico		Data: 17/06/03	Codice Progetto: PFHC5/5LCD	
Nome PC in Rete: \\UT_SRV\PROGETTI		Revisione: 2.0	Nome Parte: POWER COMBINER LAYOUT	
File/Cartella: MANUALI\HC5LCD\SLCMB1HC5LCD\LAYCPL.DWG		Autorizzazione:	Codice: SLCMB1HC5LCD	
Scala: 1:1,5	Materiale: /	Trattamento: /	Profilo: /	



5 WAY POWER COMBINER - Bill Of Materials

Item	Q.ty	Reference	Part	DESCRIPTION
1	2	R1,R2	47	RESISTOR 1/4W 5%
2	2	C1,C2	22PF	CERAMIC CAPACITOR NP0
3	5	CV1, CV2, CV3, CV4, CV5	RG303	COAX CABLE RG303
4	2	CN7, CN8	BNC TELAIO	CONN. BNC A TELAIO
5	5	CN2, CN3, CN4, CN5, CN6	CNT16FPBR	FLANGE 7/16"
6	1	CN1	FL158CU024/B	FLANGE 1 5/8"
7	16	ST1, ST2, ST3, ST4, ST5, ST6, ST7, ST8, ST9, ST10, ST11, ST12, ST13, ST14, ST15, ST16	STRIP LINE	

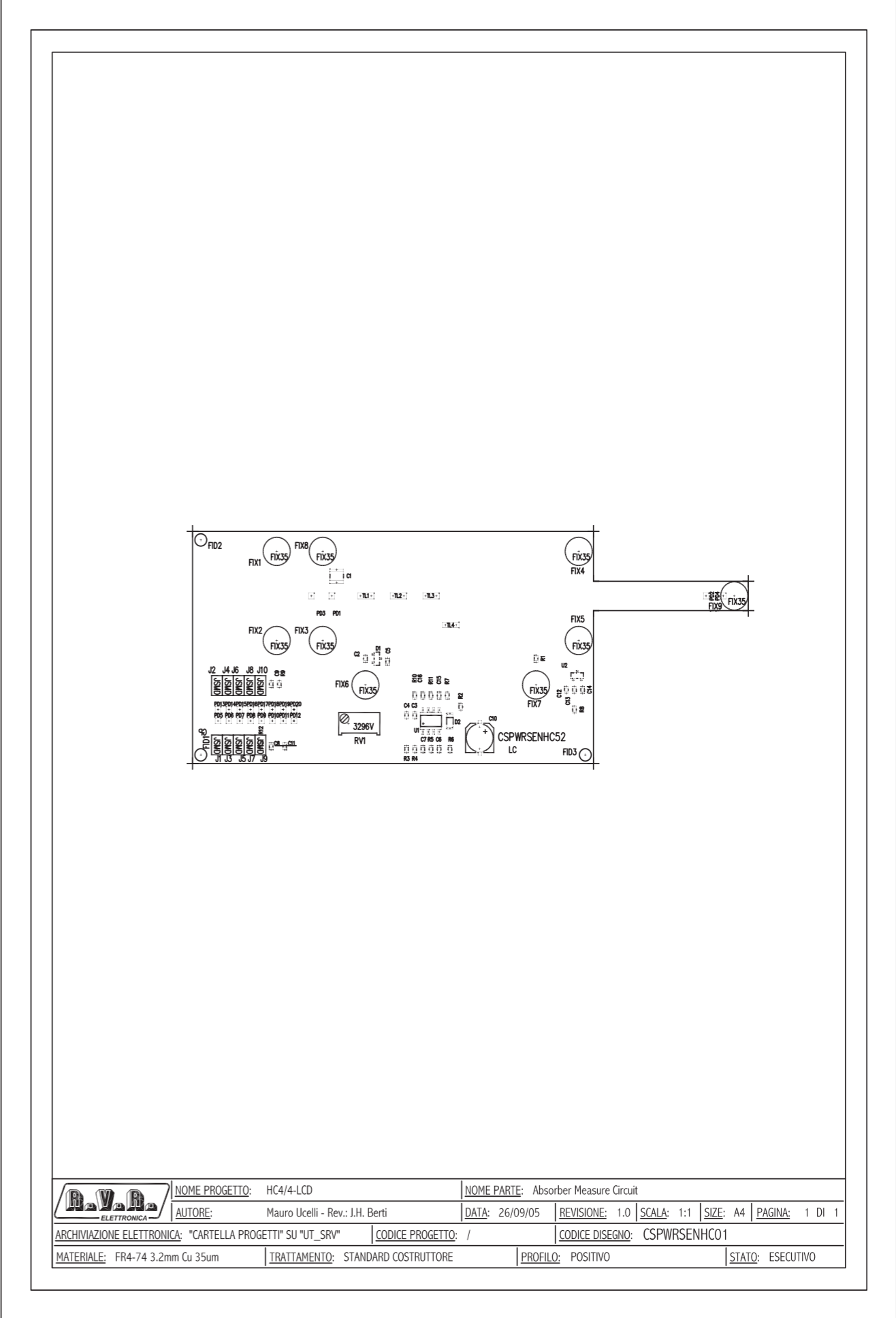
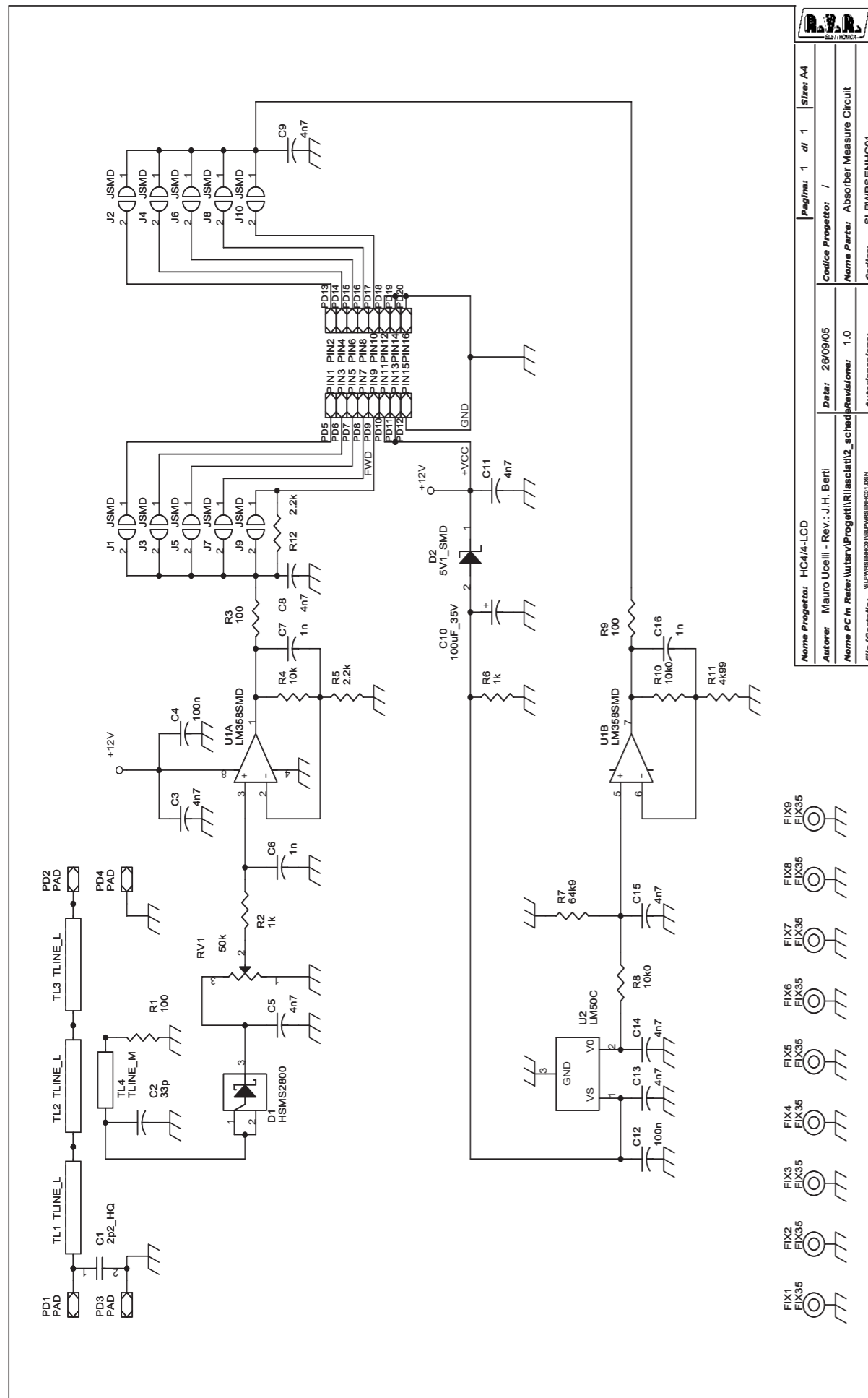

Absorber Measure Circuit Revised: Monday, September 26, 2005
SLPWRSENHC01 Revision: 1.0
HC4/4-LCD

/

Mauro Ucelli - Rev.: J.H. Berti

Item	Quantity	Reference	Part	
1	1	C1	2p2_HQ	(CSMD_HQ): Chip alto Q 2.2pF
2	1	C2	33p	(0805/0603): Cond. SMT 33pF 0805 o 0603
3	8	C3, C5, C8, C9, C11, C13, C14, C15	4n7	(0805/0603): Cond. SMT 4.7nF 0805 o 0603
4	2	C4, C12	100n	(0805/0603): Cond. SMT 100nF 0805 o 0603
5	3	C6, C7, C16	1n	(0805/0603): Cond. SMT 1nF 0805 o 0603
6	1	C10	100uF_35V	(CES6.3X8): Cond. elettrolitico alluminio SMT 100uF 35V
7	1	D1	HSMS2800	(SOT-23): Diodo SMT HSMS2800
8	1	D2	5V1_SMD	(MINIMELF): Diodo Zener SMT 5.1V
9	9	FIX1, FIX2, FIX3, FIX4, FIX5, FIX6, FIX7, FIX8, FIX9	FIX35	(FIX35): Non è un componente
10	10	J1, J2, J3, J4, J5, J6, J7, J8, J9, J10	J5MD	(J5MD): Non è un componente
11	4	PD1, PD2, PD3, PD4	PAD	(PD): Non è un componente
12	1	PD5	PIN1	(PD): Non è un componente
13	1	PD6	PIN2	(PD): Non è un componente
14	1	PD7	PIN3	(PD): Non è un componente
15	1	PD8	PIN4	(PD): Non è un componente
16	1	PD9	PIN5	(PD): Non è un componente
17	1	PD10	PIN6	(PD): Non è un componente
18	1	PD11	PIN7	(PD): Non è un componente
19	1	PD12	PIN8	(PD): Non è un componente
20	1	PD13	PIN9	(PD): Non è un componente
21	1	PD14	PIN10	(PD): Non è un componente
22	1	PD15	PIN11	(PD): Non è un componente
23	1	PD16	PIN12	(PD): Non è un componente
24	1	PD17	PIN13	(PD): Non è un componente
25	1	PD18	PIN14	(PD): Non è un componente
26	1	PD19	PIN15	(PD): Non è un componente
27	1	PD20	PIN16	(PD): Non è un componente
28	1	RV1	50k	(3296V): Trimmer resistivo multigiri vite in testa
29	3	R1, R3, R9	100	(0805/0603): Res. SMT 100 Ohm 1%
30	2	R2, R6	1k	(0805/0603): Res. SMT 1k 1%
31	1	R4	10k	(0805/0603): Res. SMT 10k 1%
32	2	R5, R12	2.2k	(0805/0603): Res. SMT 2.2k 1%
33	1	R7	64k9	(0805/0603): Res. SMT 64.9k 1%
34	2	R8, R10	10k0	(0805/0603): Res. SMT 10k 1%
35	1	R11	4k99	(0805/0603): Res. SMT 4.99k 1%
36	3	TL1, TL2, TL3	TLINE_L	
37	1	TL4	TLINE_M	
38	1	U1	LM358SMD	(SO-8): IC SMT LM358
39	1	U2	LM50C	(SOT-23): IC SMT LM50C

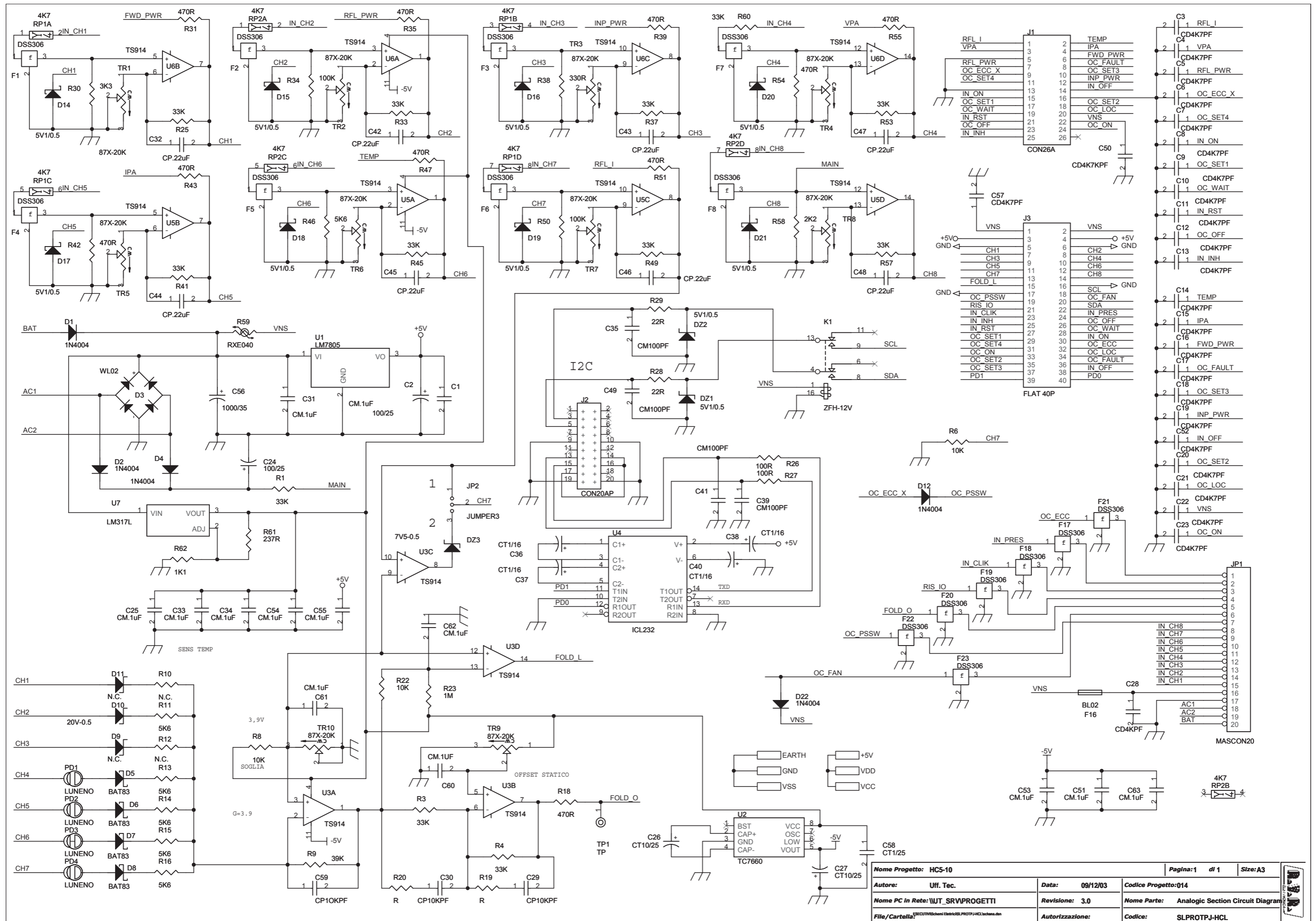

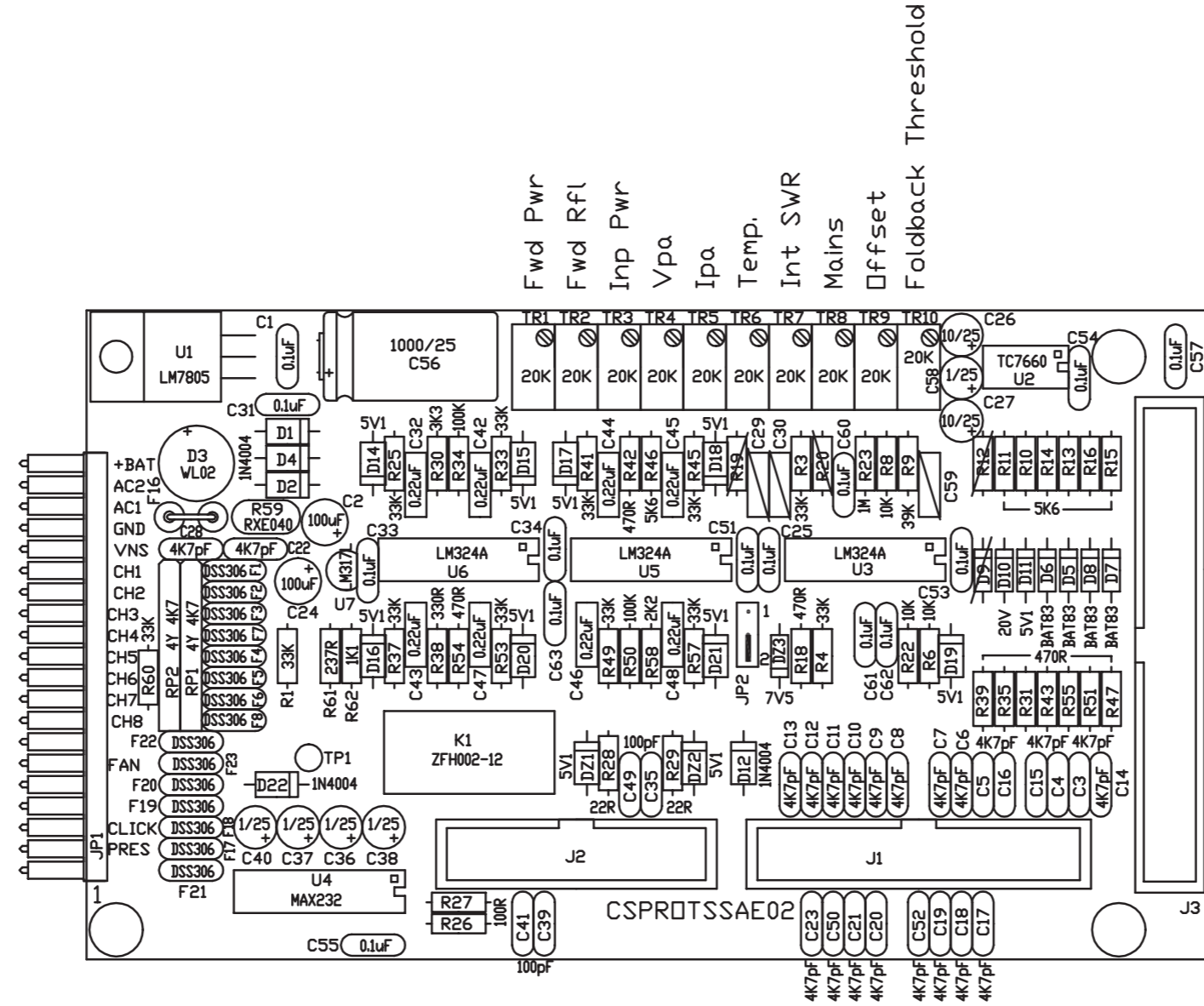

Fwd Pwr
Fwd Rfl
Inp Pwr
Vpa
Ipa
Temp.
Int SWR
Mains
Offset
Foldback Threshold

NOME PROGETTO: HC5-10		NOME PARTE: Analogic Section Component Layout	
AUTORE: GP - Rev.: J. Berti		DATA: 11/02/2004	
ARCHIVIAZIONE ELETTRONICA: "CARTELLA PROGETTI" SU "UT_SRV"		REVISIONE: 2.0	SCALA: 1:1
MATERIALE: FR4-74 1.6mm Cu 35um		TRATTAMENTO: STANDARD COSTRUTTORE	CODICE DISEGNO: PROTPJ-HCLCD
		PROFILO: Positivo	STATO: ESECUTIVO
		SIZE: A4	PAGINA: 1 DI 1

PROTPJ-HCL

CPU Analog Section
 SLPROTPJ-HCL
 Version: 2.2 Date: 04/09/03

Item	Q.ty	Reference	Part
1	13	C1,C25,C31,C33,C34,C51,C53,C54,C55,C60,C61,C62,C63	CM.1uF
2	2	C24,C2	100/25
3	23	C3,C4,C5,C6,C7,C8,C9,C10,C11,C12,C13,C14,C15,C16,C17,C18,C19,C20,C21,C22,C23,C52,C57	CD4K7PF
4	2	C26,C27	CT10/25
5	1	C28	CD4KPF
7	8	C32, C42, C43, C44, C45, C46, C47, C48	CP.22uF
8	4	C35, C39, C41, C49	CM100PF
9	4	C36, C37, C38, C40	CT1/16
10	1	C50	CD4K7KPF
11	1	C56	1000/35
12	1	C58	CT1/25
13	1	C59	CP10KPF
14	10	DZ1, DZ2, D14, D15, D16, D17, D18, D19, D20, D21	5V1/0.5
15	1	DZ3	7V5-0.5
16	5	D1, D2, D4, D12, D22	1N4004
17	1	D3	WL02
18	4	D5, D6, D7, D8	BAT83
19	4	R10, R12, D9, D11	N.C.
20	1	D10	20V-0.5
21	15	F1, F2, F3, F4, F5, F6, F7, F8, F17, F18, F19, F20, F21, F22, F23	DSS306
22	1	F16	BL02
23	1	JP1	MASCON20
24	1	JP2	JUMPER3
25	1	J1	CON26A
26	1	J2	CON20AP
27	1	J3	FLAT 40P
28	1	K1	ZFH-12V
29	4	PD1, PD2, PD3, PD4	LUNENO
30	2	RP1, RP2	4K7
31	12	R1, R3, R4, R25, R33, R37, R41, R45, R49, R53, R57, R60	33K
32	3	R6, R8, R22	10K
33	1	R9	39K
34	6	R11, R13, R14, R15, R16, R46	5K6
35	10	R18, R31, R35, R39, R42, R43, R47, R51, R54, R55	470R
36	2	R19, R20	R
37	1	R23	1M
38	2	R26, R27	100R
39	2	R28, R29	22R
40	1	R30	3K3
41	2	R50, R34	100K
42	1	R38	330R
43	1	R58	2K2
44	1	R59	RXE040
45	1	R61	237R
46	1	R62	1K1
47	1	TP1	TP

5	1	C28	CD4KPF
7	8	C32, C42, C43, C44, C45, C46, C47, C48	CP.22uF
48	10	TR1, TR2, TR3, TR4, TR5, TR6, TR7, TR8, TR9, TR10	87X-20K
49	1	U1	LM7805
50	1	U2	TC7660
51	3	U3, U5, U6	TS914
52	1	U4	ICL232
53	1	U7	LM317L

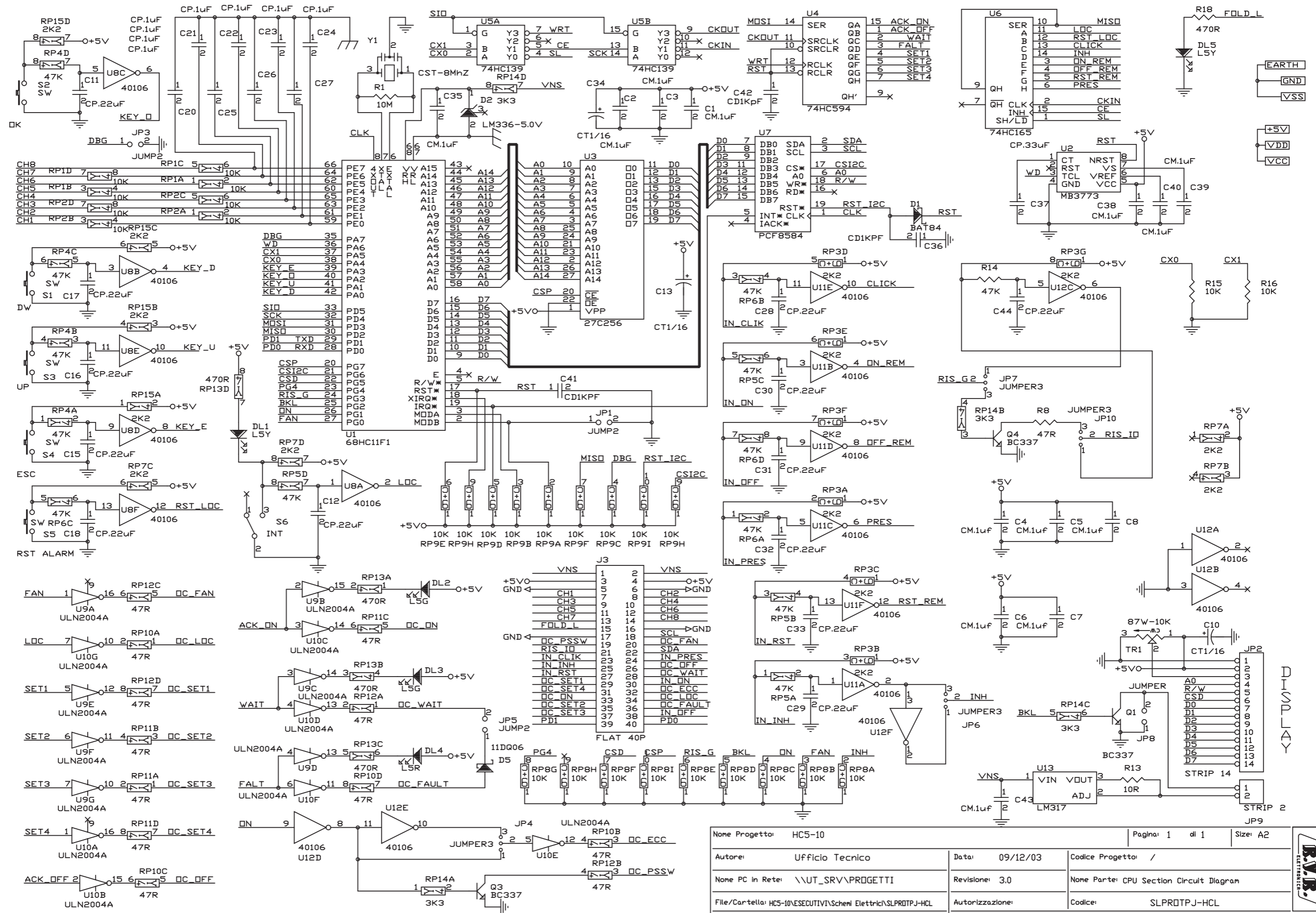

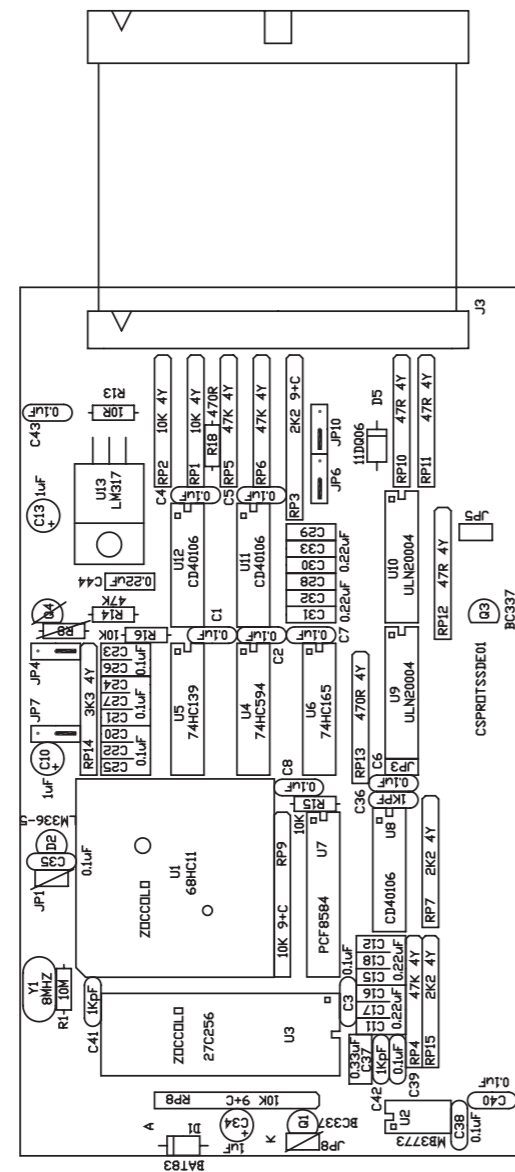

Scheda CPU
SLPROTPJ-HCL
Versione: 2.2

Item	Q.ty	Reference	Description
1	13	C1,C2,C3,C4,C5,C6,C7,C8,C35,C38,C39,C40,C43	CM.1UF
2	3	C10,C13,C34	CT1/16
3	13	C11,C12,C15,C16,C17,C18,C28,C29,C30,C31,C32,C33,C44	CP.22UF
4	8	C20,C21,C22,C23,C24,C25,C26,C27	CP.1UF
5	3	C36, C41, C42	CD1KPF
7	2	DL1, DL5	L5Y
8	2	DL2, DL3	L5G
9	1	DL4	L5R
10	1	D1	BAT84
11	1	D2	LM336-5.0V
12	1	D5	11DQ06
13	3	JP1, JP3, JP5	JUMP2
14	1	JP2	STRIP 14
15	4	JP4, JP6, JP7, JP10	JUMPER3
16	1	JP8	JUMPER
17	1	JP9	STRIP 2
18	1	J3	FLAT 40P
19	3	Q1, Q3, Q4	BC337
20	6	RP1, RP2, RP8, RP9, R15, R16	10K
21	3	RP3, RP7, RP15	2K2
22	4	RP4, RP5, RP6, R14	47K
23	4	R8, RP10, RP11, RP12	47R
24	2	RP13, R18	470R
25	1	RP14	3K3
26	1	R1	10M
27	1	R13	10R
28	5	S1, S2, S3, S4, S5	SW
29	1	S6	INT
30	1	TR1	87W-10K
31	1	U1	68HC11F1
32	1	U2	MB3773
33	1	U3	27C256
34	1	U4	74HC594
35	1	U5	74HC139
36	1	U6	74HC165
37	1	U7	PCF8584
38	3	U8, U11, U12	40106
39	2	U9, U10	ULN2004A
40	1	U13	LM317
41	1	Y1	CST-8MHZ

	NOME PROGETTO: HC5-10	NOME PARTE: LCD Alarms Card Layout
AUTORE: GP - Rev.: J. Berti	DATA: 11/02/2004	REVISIONE: 1.0
ARCHIVIAZIONE ELETTRONICA: "CARTELLA PROGETTI" SU "UT_SRV"	CODICE PROGETTO: 014	CODICE DISEGNO: SLPROTPJ-HCL
MATERIALE: FR4-74 1.6mm Cu 35um	TRATTAMENTO: STANDARD COSTRUTTORE	PROFILO: Positivo
		STATO: ESECUTIVO

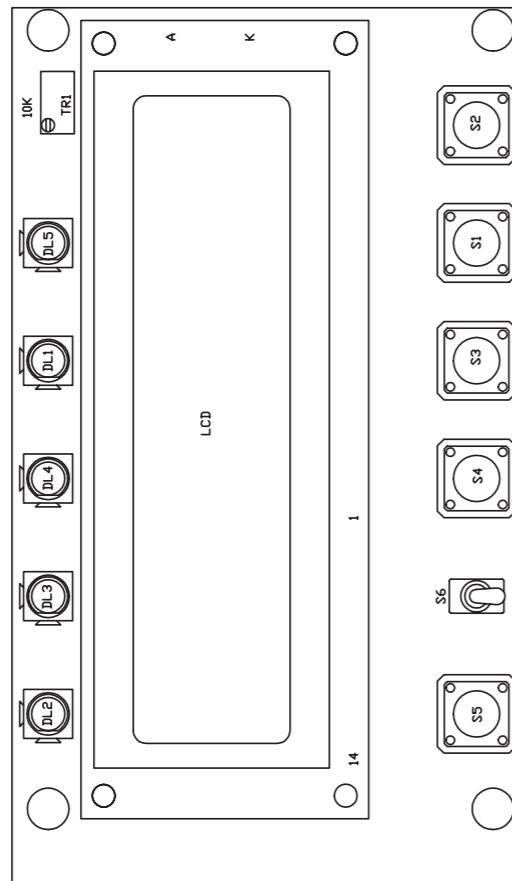

	NOME PROGETTO: HC5-10	NOME PARTE: CPU Display Section Component Layout			
	AUTORE: GP - Rev.: J. Berti	DATA: 11/02/2004	REVISIONE: 2.0	SCALA: 1:1	SIZE: A4
ARCHIVIAZIONE ELETTRONICA: "CARTELLA PROGETTI" SU "UT_SRV"		CODICE PROGETTO: 014	CODICE DISEGNO: PROTPJ-HCLCD		
MATERIALE: FR4-74 1.6mm Cu 35um	TRATTAMENTO: STANDARD COSTRUTTORE	PROFILO: Positivo	STATO: ESECUTIVO		

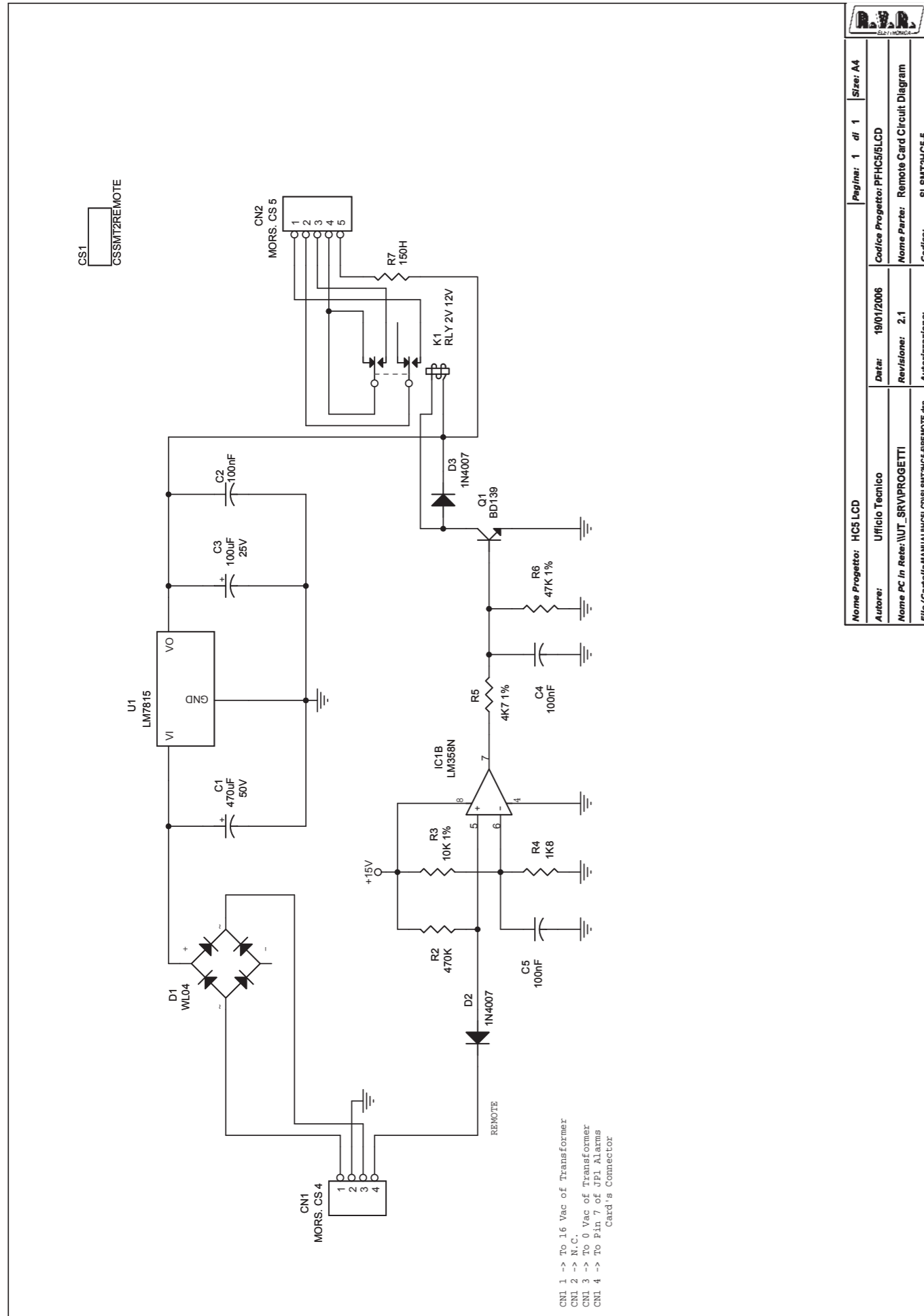

Nome Progetto: HC5 LCD		Pagina: 1 di 1		Size: A4
Autore: Ufficio Tecnico		Data: 19/01/2006		Codice Progetto: PFHC5/SLCD
Nome PC in Rete: \UT_SRVPROGETTI		Revisione: 2.1		Nome Parte: Remote Card Circuit Diagram
File/Cartella\MANUAL\HCSLCD\SLSMT2HC5-5\REMOTE.dsn		Autorizzazione:		Codice: SLSMT2HC5-5

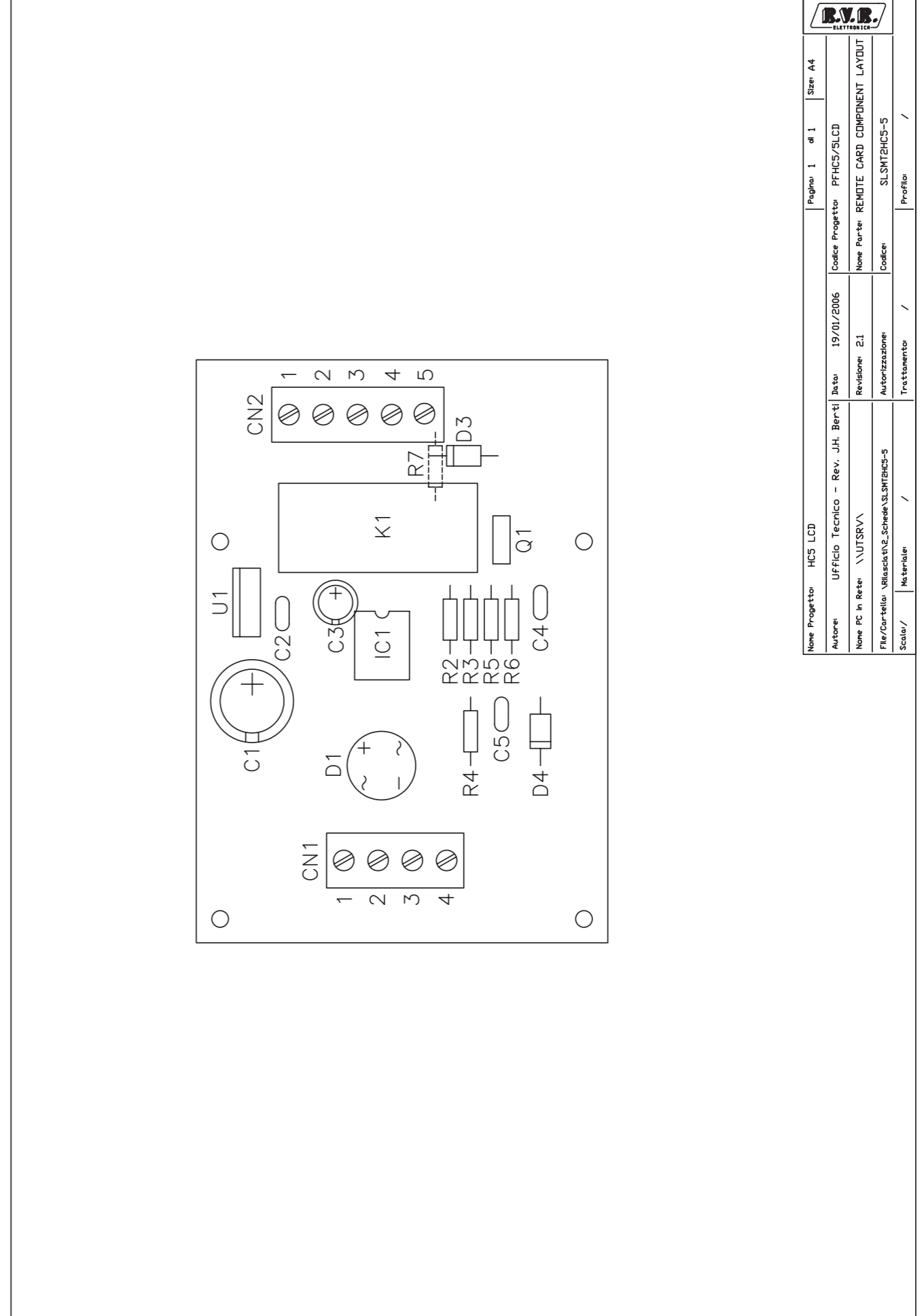

Nome Progetto: HC5 LCD		Pagina: 1 di 1		Size: A4
Autore: Ufficio Tecnico - Rev. J.H. Bertl		Data: 19/01/2006		Codice Progetto: PFHC5/SLCD
Nome PC in Rete: \\UTSRV\		Revisione: 2.1		Nome Parte: REMOTE CARD COMPONENT LAYOUT
File/Cartella \Rilascio\12_Schede\SLSMT2HC5-5		Autorizzazione:		Codice: SLSMT2HC5-5
Scala:	Materiale:	Trattamento:	Profilo:	/

Remote Card Circuit Diagram Revised: Thursday, January 19, 2006

SLSMT2HC5-5 Revision: 2.1

HC5 LCD

PFHC5/5LCD

Ufficio Tecnico

Item	Quantity	Reference	Part	
1	1	CN1	MORS. CS 4	CONN. MASCHIO CS 4 VIE PHOENIX
2	1	CN2	MORS. CS 5	CONN. MASCHIO CS 5 VIE PHOENIX
3	1	CS1	CSSMT2REMOTE	CIRCUITO STAMPATO
4	1	C1	470uF	COND.EL.AL.V. 470MF 35V P5,08 20%
5	1	C3	100uF	COND.EL.AL.V. 100MF 25V P2,54 20%
6	3	C2, C4, C5	100nF	COND.MULTISTR.100NF 20% 5,08MM 50V
7	1	D1	WL04	PONTE RADDRIZZATORE MODELLO WL02
8	2	D2, D3	1N4007	DIODO AL SILICIO 1000V 1AMP. 1N4007
9	1	IC1	LM358N	CIRC. INT. LINEARE LM358N
10	1	K1	RLY 2V 12V	RELAY DUAL IN LINE 2V 12V 5A HERMET.
11	1	Q1	BD139	TRANSISTOR BD139
12	1	R2	470K	RES. STRATO METALLICO 1/4W 1% 470K
13	1	R3	10K 1%	RES. STRATO METALLICO 1/4W 1% 10K
14	1	R4	1K8	RES. STRATO METALLICO 1/4W 1% 1K8
15	1	R5	4K7 1%	RES. STRATO METALLICO 1/4W 1% 4K7
16	1	R6	47K 1%	RES. STRATO METALLICO 1/4W 1% 47K
17	1	R7	150H	RES. STRATO METALLICO 1/4W 1% 150H
18	1	U1	LM7815	CIRC. INT. LINEARE 7815 1A (TO220)

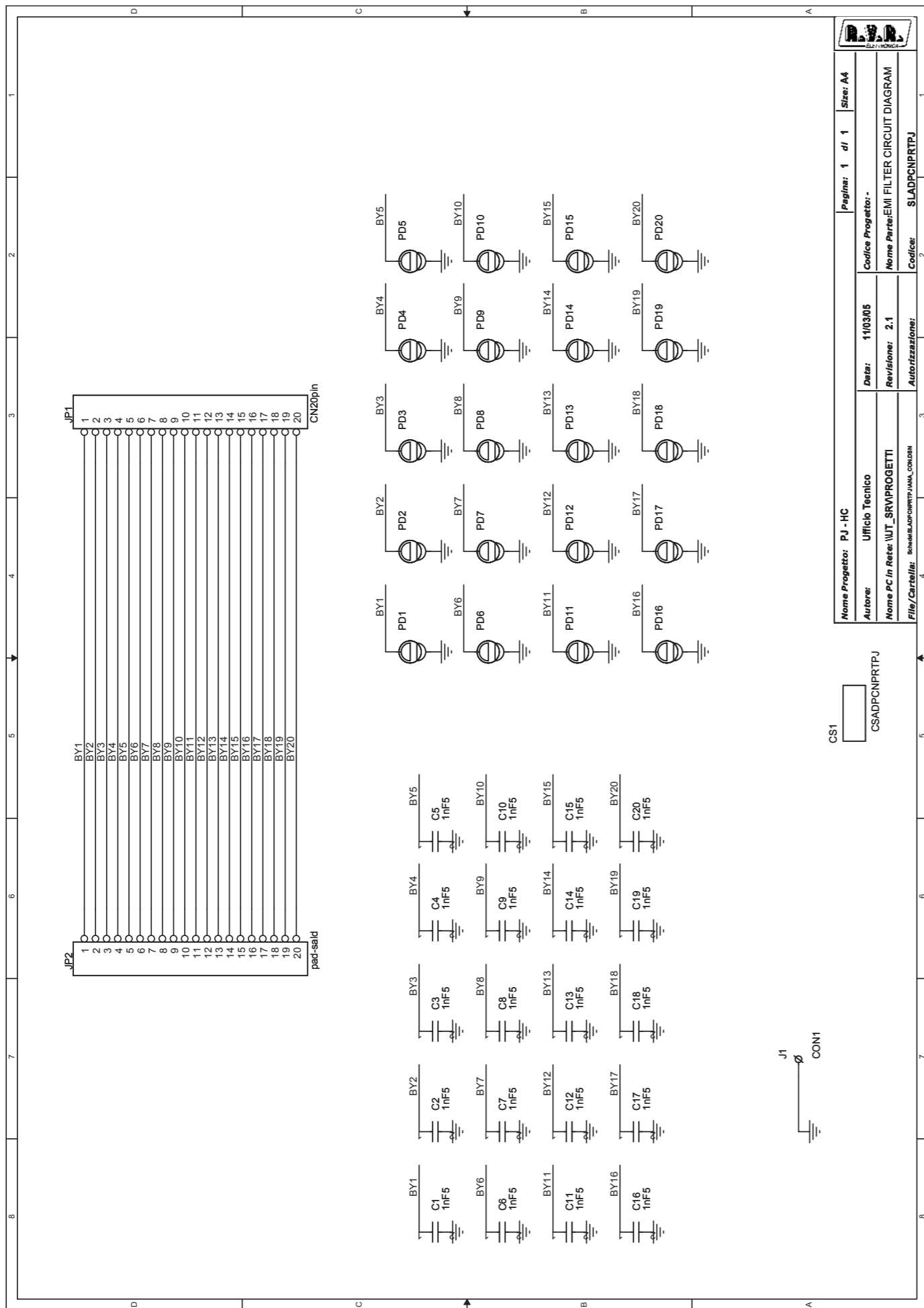

R.V.R. ELETTRONICA	
Nome Progettista: PJ - HC	Pagina: 1 di 1
Autore: Ufficio Tecnico	Size: A4
Nome PC In Rete: \UT_SRVPROGETTI	Data: 11/03/05
File/Cartella: sbaaslapcnp_rtpj\ank_cozan	Revisione: 2.1
	Autore: EMI FILTER CIRCUIT DIAGRAM
	Nome Progetto: SLADPCNPRTPJ
	Codice: 2

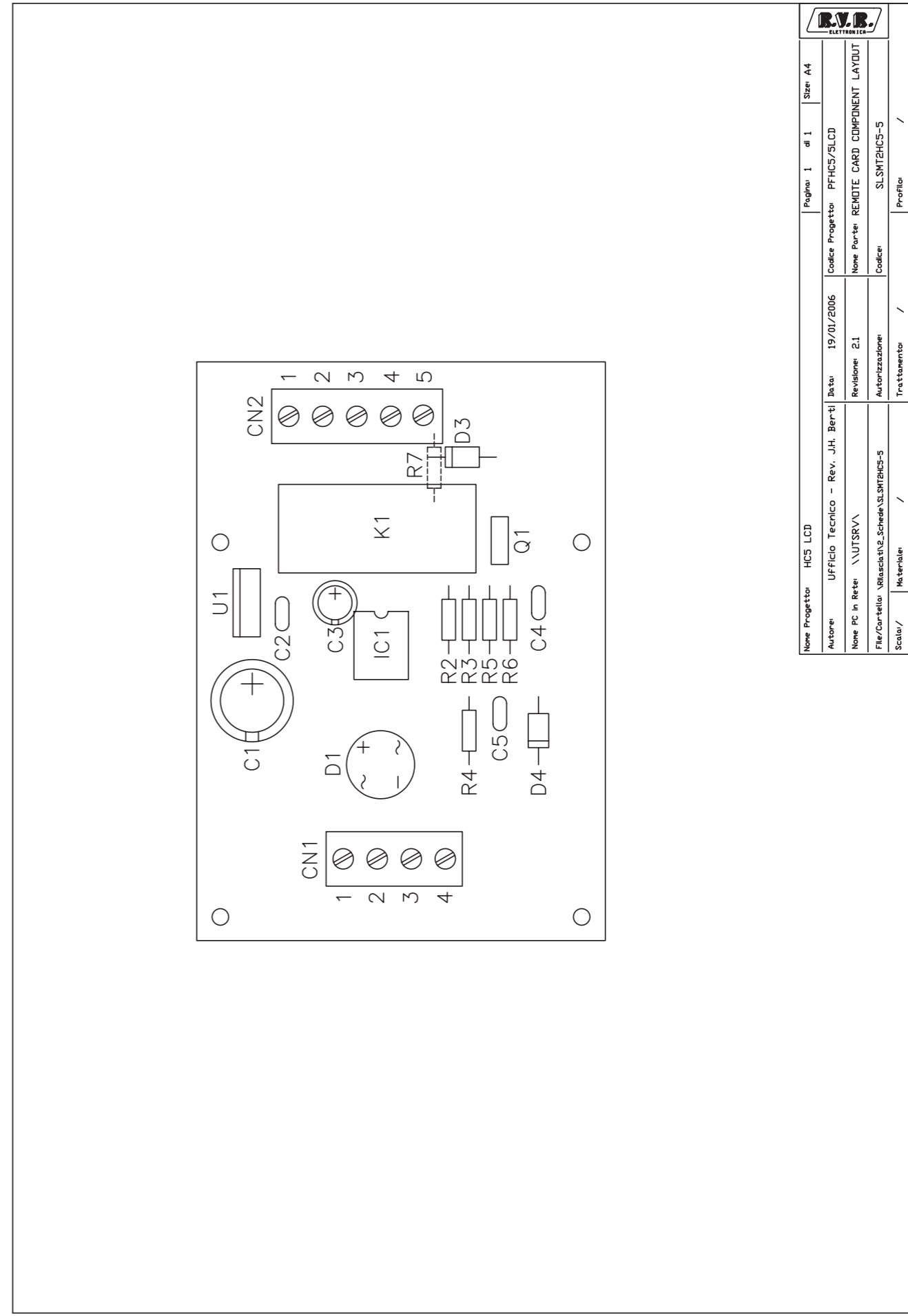

R.V.R. ELETTRONICA	
Nome Progetto: HC5 LCD	Pagina: 1 di 1
Autore: Ufficio Tecnico - Rev. J.H. Bertl	Size: A4
Nome PC In Rete: \UTSRV	Data: 19/01/2006
File/Cartella: \Rilascio t.r.e. Scheda SL5MT2HC5-5	Revisione: 2.1
	Autore: REMOTE CARD COMPONENT LAYOUT
	Nome Progetto: SL5MT2HC5-5
	Codice: /
	Trattamento: /
	Profilo: /

Remote Card Circuit Diagram Revised: Thursday, January 19, 2006

SLSMT2HC5-5 Revision: 2.1

HC5 LCD

PFHC5/5LCD

Ufficio Tecnico

Item	Quantity	Reference	Part	
1	1	CN1	MORS. CS 4	CONN. MASCHIO CS 4 VIE PHOENIX
2	1	CN2	MORS. CS 5	CONN. MASCHIO CS 5 VIE PHOENIX
3	1	CS1	CSSMT2REMOTE	CIRCUITO STAMPATO
4	1	C1	470uF	COND.EL.AL.V. 470MF 35V P5,08 20%
5	1	C3	100uF	COND.EL.AL.V. 100MF 25V P2,54 20%
6	3	C2, C4, C5	100nF	COND.MULTISTR.100NF 20% 5,08MM 50V
7	1	D1	WL04	PONTE RADDRIZZATORE MODELLO WL02
8	2	D2, D3	1N4007	DIODO AL SILICIO 1000V 1AMP. 1N4007
9	1	IC1	LM358N	CIRC. INT. LINEARE LM358N
10	1	K1	RLY 2V 12V	RELAY DUAL IN LINE 2V 12V 5A ERMET.
11	1	Q1	BD139	TRANSISTOR BD139
12	1	R2	470K	RES. STRATO METALLICO 1/4W 1% 470K
13	1	R3	10K 1%	RES. STRATO METALLICO 1/4W 1% 10K
14	1	R4	1K8	RES. STRATO METALLICO 1/4W 1% 1K8
15	1	R5	4K7 1%	RES. STRATO METALLICO 1/4W 1% 4K7
16	1	R6	47K 1%	RES. STRATO METALLICO 1/4W 1% 47K
17	1	R7	150H	RES. STRATO METALLICO 1/4W 1% 150H
18	1	U1	LM7815	CIRC. INT. LINEARE 7815 1A (TO220)

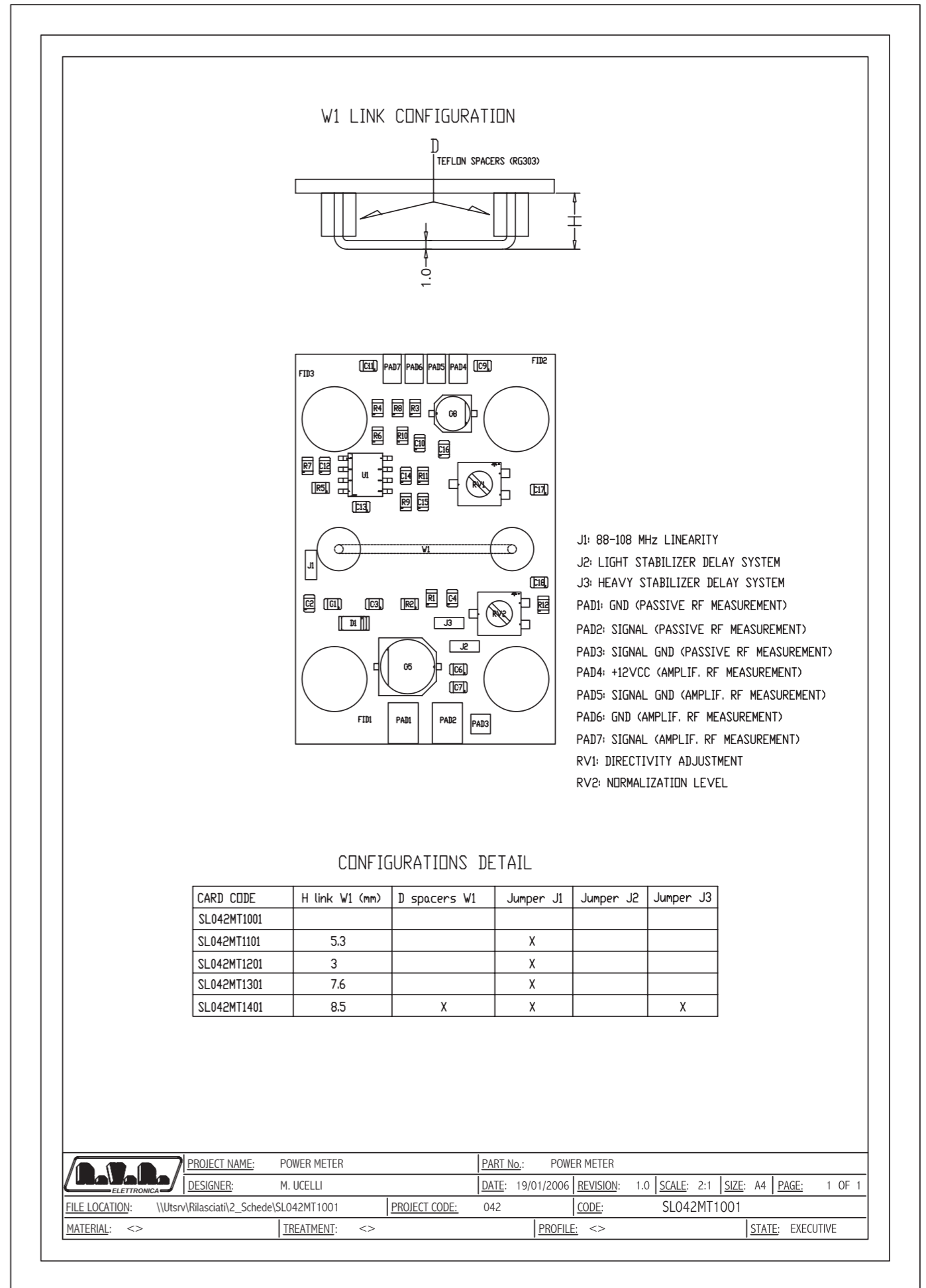
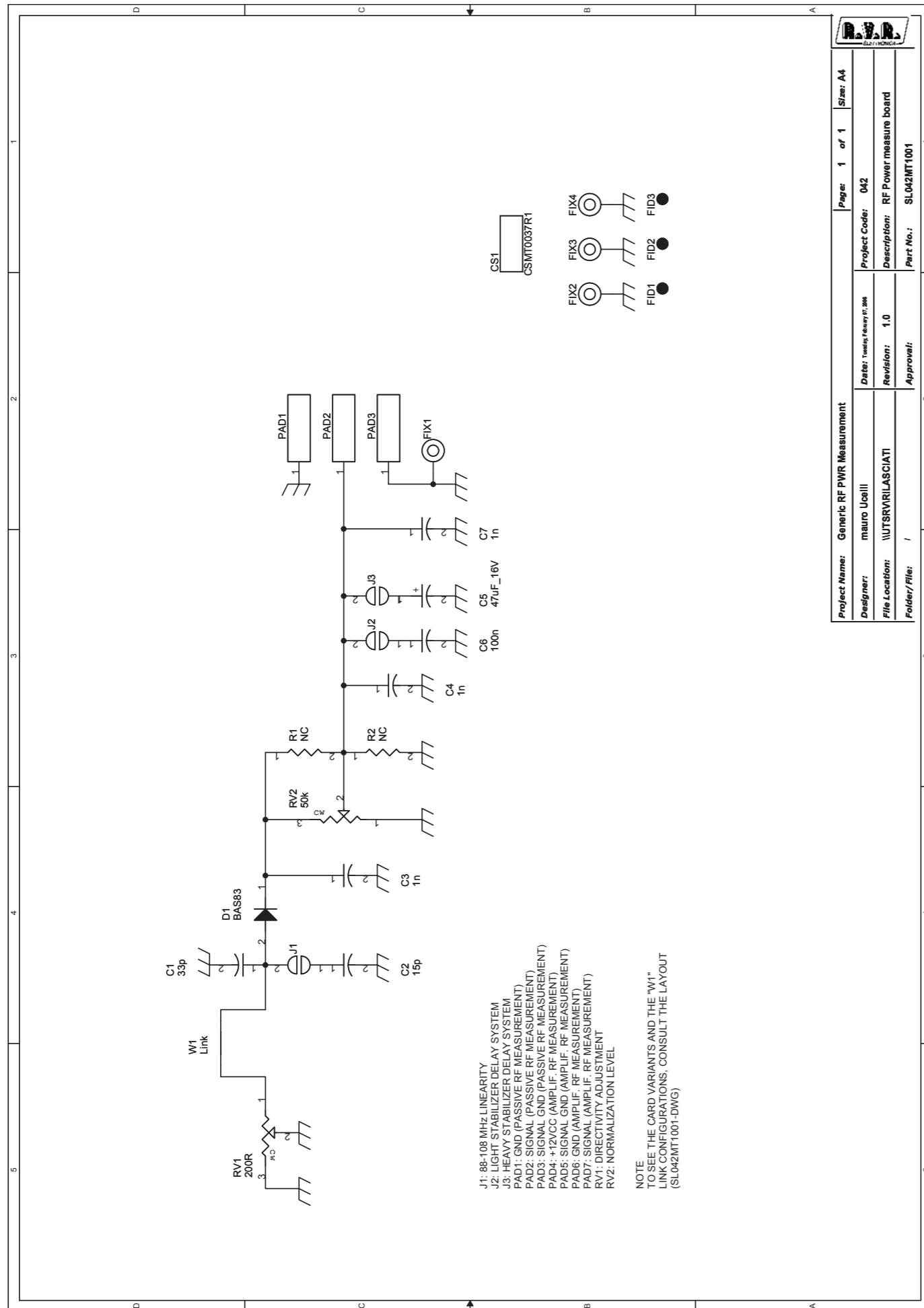

RF Power measure board
 SL042MT1001
 Revision: 1.0
 Generic RF PWR Measurement
 042
 Mauro Ucelli
 19/01/2006

Item	Quantity	Reference	Part	Description	Code1
1	1	CS1	CSMT0037R1	Printed Circuit Board	CSMT0037R1
2	1	C1	33p	SMD 0805 COG Capacitor	CCC085330JCC
3	1	C2	15p	SMD 0805 COG Capacitor	CCC085150JCC
4	3	C3,C4,C7	1n	SMD 0805 Capacitor	CCC085102JNC
5	1	C5	47uF_16V	Elect. SMD d. 6.3mm Cap.	CES476C160
6	1	C6	100n	SMD 0805 Capacitor	CCC085104KXC
7	1	D1	BAS83	MINIMELF SMD Diode	DHCBAS83
8	3	FID1,FID2,FID3	FID		
9	4	FIX1,FIX2,FIX3,FIX4	FIX35	Fixing Hole 3.5mm	
10	3	J1,J2,J3	JSMD	SMD Pad to solder	
11	3	PAD1,PAD2,PAD3	PAD		
12	1	RV1	200R	Trimmer SMD	RVT4X4H0200V
13	1	RV2	50k	Trimmer SMD	RVT4X4K0050V
14	2	R1,R2	NC	SMD 0805 Res.	
15	1	W1	Link	Wire to solder	See the Layout

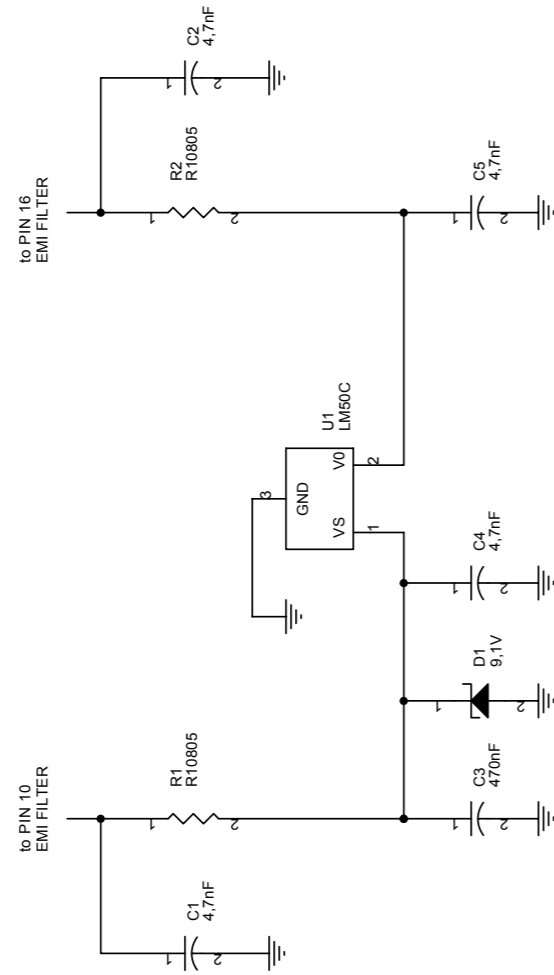

Nome Progetto: HC3 LCD		Pagina: 1 di 1		Size: A4
Autore: Ufficio Tecnico		Data: 16/06/03		Codice Progetto: PFHC3/LCD
Nome PC in Rete: \UT_SRV\PROGETTI		Revisione: 2.0		Nome Parte: Sonda Termica
File/Cartella:Manual\HC3LCD\SLSONDTERM\SLSONDTERM.dwg		Autorizzazione:		Codice: SLSONDTERM

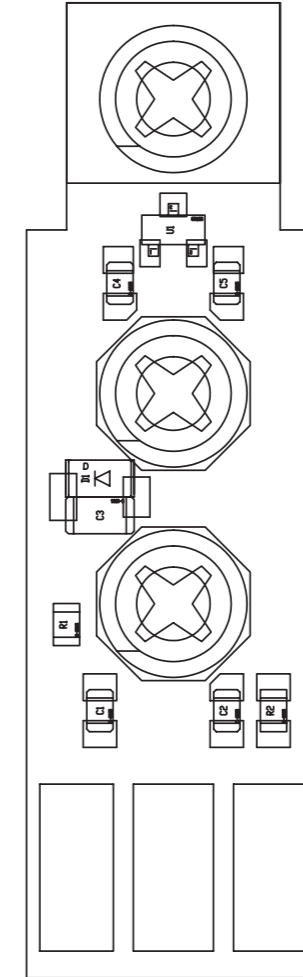

Nome Progetto: HC3 LCD		Pagina: 1 di 1		Size: A4
Autore: Ufficio Tecnico		Data: 16/06/03		Codice Progetto: PFHC3/LCD
Nome PC in Rete: \UT_SRV\PROGETTI		Revisione: 2.0		Nome Parte: SONDA TERMICA
File/Cartella:Manual\HC3LCD\SLSONDTERM\CSSTERM.DWG		Autorizzazione:		Codice: SLSONDTERM
Scala: 3:1	Materiali:	Trattamento:	Profilo:	/

Sonda Termica
SLSONDTERM
Revision: 2.0
Ufficio Tecnico
17/06/03

Item	Quantity	Reference	Part	Description
1	4	C1,C2,C4,C5	4,7nF	Cond. SMD 0805
2	1	C3	470nF	Cond. SMD 1206
3	1	D1	9,1V	MINIMELF SMD Zener Diode
4	2	R1,R2	R10805	Res. SMD 0805
5	1	U1	LM50C	Temperature sensor